

# SpeedyBee F405 Mini BLS 35A 20x20 Stack User Manual V1.0

Contents (Click on any section to jump)

Part 1 - OverView	1
▪ Specs Overview	1
▪ Dimensions	2
▪ Package	3
▪ FC & ESC Connection	4
Part 2 - SpeedyBee F405 Mini Flight Controller	5
▪ Layout	5
▪ FC's Peripheral Connection	6
▪ App & FC Configuration	7
▪ FC Firmware Update	8
▪ Specifications	9
Part 3 - SpeedyBee BLS 35A Mini V2 4-in-1 ESC	10
▪ Layout	10
▪ Connection with Motors & Power Cable	11
▪ ESC Configuration	12
▪ ESC Firmware Update	13
▪ Specifications	14

1/14

## Part 1 Overview

### Specs Overview

1/14

Product Name	SpeedyBee F405 Mini BLS 35A 20x20 Stack
Flight Controller	SpeedyBee F405 Mini
ESC	SpeedyBee BLS 35A Mini V2 4-in-1 ESC
Bluetooth	Supported. Used to connect with the SpeedyBee App for flight controller and ESC parameter configuration. <b>Please make sure the MSP switch on UART 4 is turned on and set to a baud rate of 115200, otherwise Bluetooth functionality will not be available.</b>
WiFi	NOT Supported
Wireless FC Firmware Flashing	NOT Supported
Wireless Blackbox Dwonload & Analysis	NOT Supported
Power Input	3-6S LiPo
Mounting	20 x 20mm $\Phi$ 3.5mm hole size, <b>Compatible with M2 and M3 screws/Silicone grommets.</b>
Dimension	32mm(L) x 35mm(W) x 15.2mm(H)
Weight	13.5g

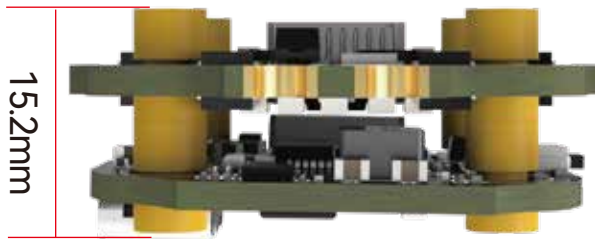
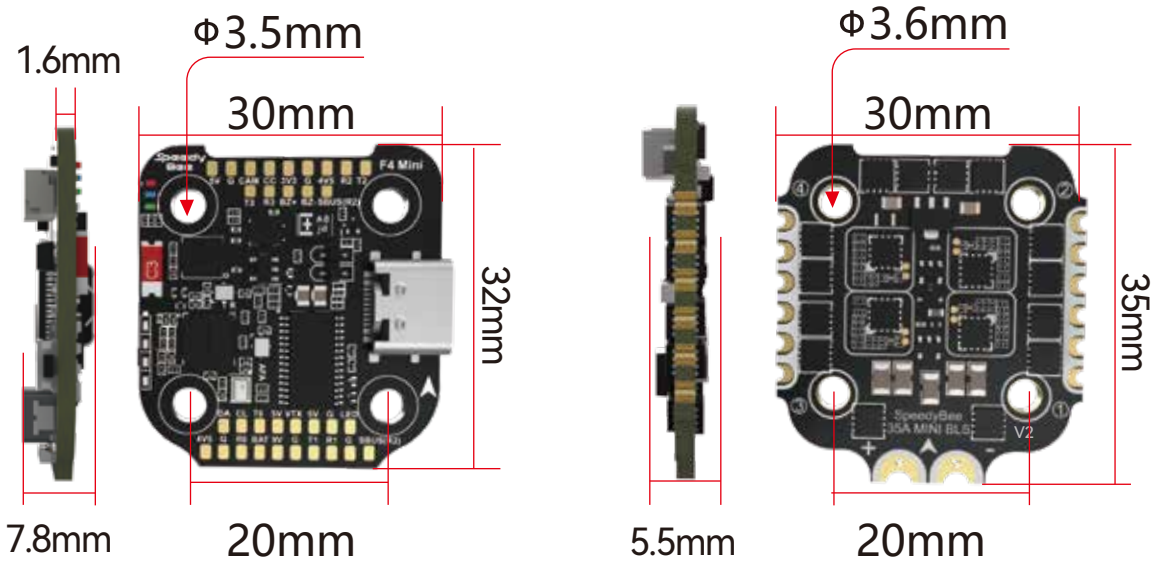

- 1 SpeedyBee F405 Mini Flight Controller x 1
- 2 SpeedyBee 35A BLHeliS Mini V2 4-in-1 ESC x 1
- 3 Manual & App Download Card x 1
- 4 35V 470uF Capacitor x 1
- 5 8pin JST cable(For FC & ESC Connection) x 1
- 6 DJI 6-pin Cable(80mm) x 1
- 7 XT30 Power Cable(Length: 7cm) x 1

## M2 Accessories

- 8 M2 Silicone O-Ring x 5
- 9 M2 Nylon Hex Nut x 5
- 10 M2(Hole Diameter) \* 7.6mm(Height) Anti-vibration Silicone Grommets x 9
- 11 M2(Diameter) \* 25mm(Length) Screw x 4
- 12 M2(Diameter) \* 20mm(Length) Screw x 4

## M3 Accessories

- 13 M3 Silicone O-Ring x 5
- 14 M3 Nylon Hex Nut x 5
- 15 M3(Hole Diameter) \* 6.6mm(Height) Anti-vibration Silicone Grommets x 9
- 16 M3(Diameter) \* 25mm(Length) Screw x 4
- 17 M3(Diameter) \* 20mm(Length) Screw x 4

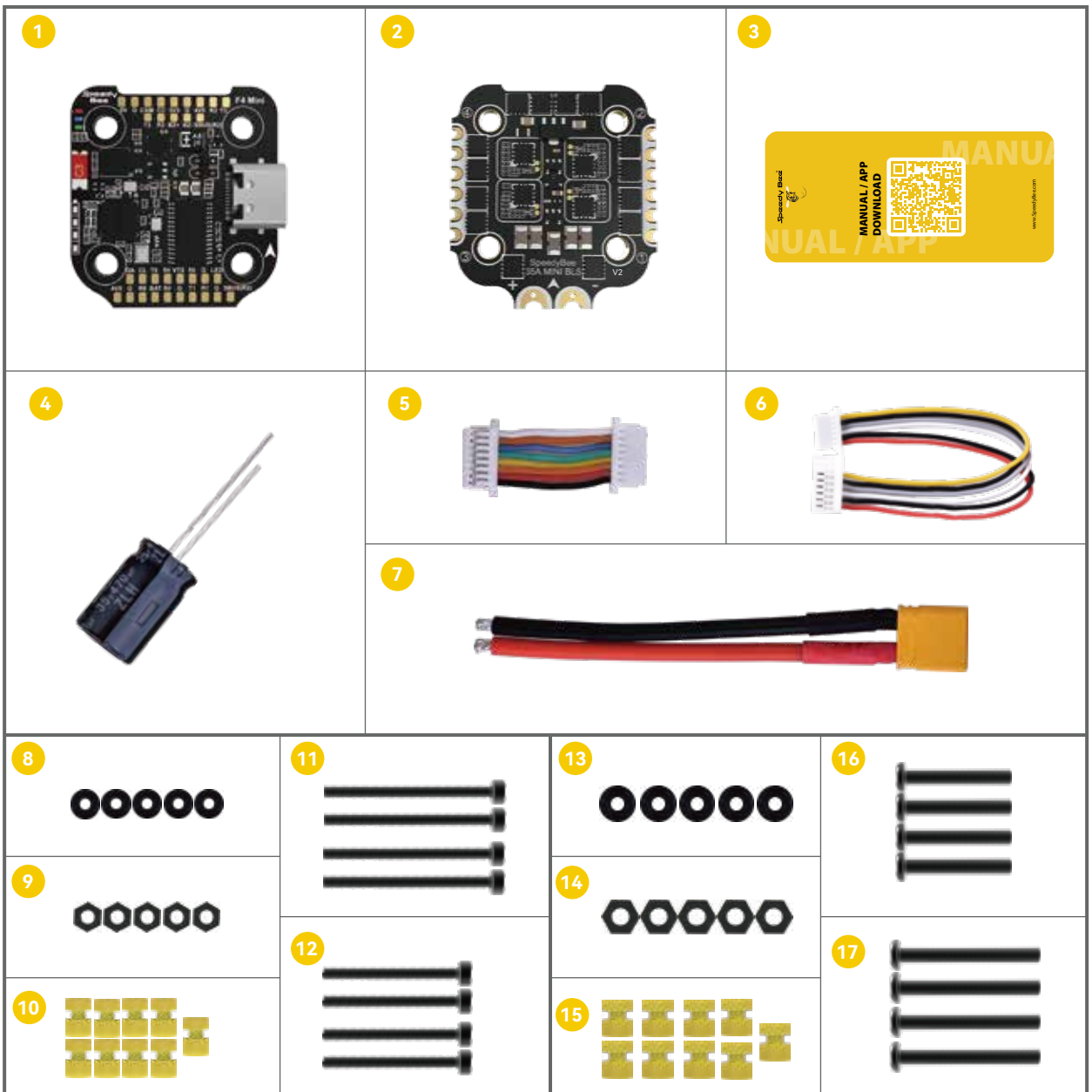

Use the 8-pin cable in the package to connect the FC and the ESC. Or solder 8 wires directly to the 8 pads on each end.

## Method 1 - Using 8-pin cable

Use any end of the 8-pin JST cable to connect the FC to the ESC.

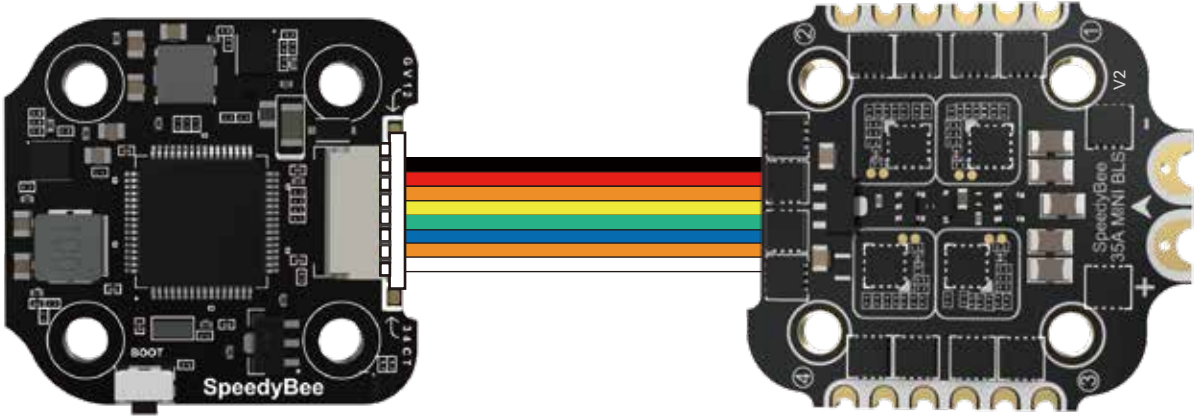

F405 Mini Flight Controller

BLS 35A Mini V2 4-in-1 ESC

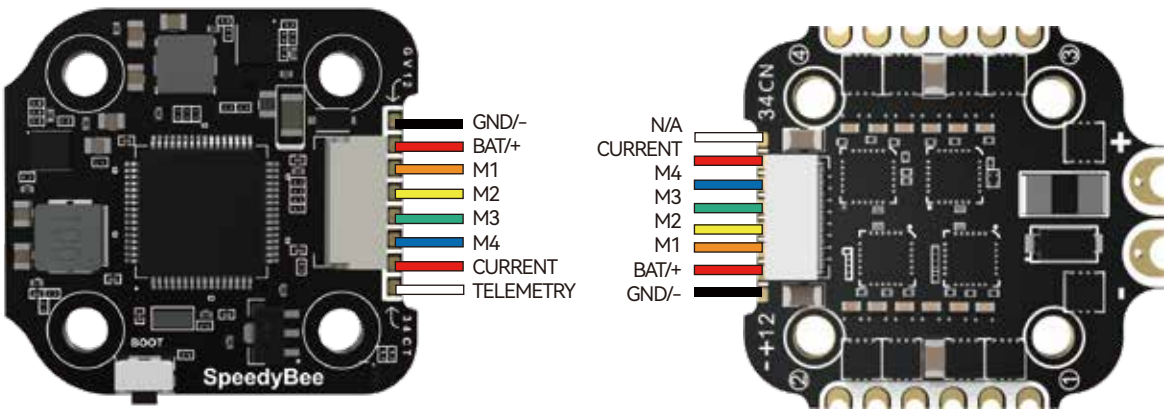

## Method 2 - Direct soldering

Solder 8 wires to the 8 pads on each end referring to the pad definition below.

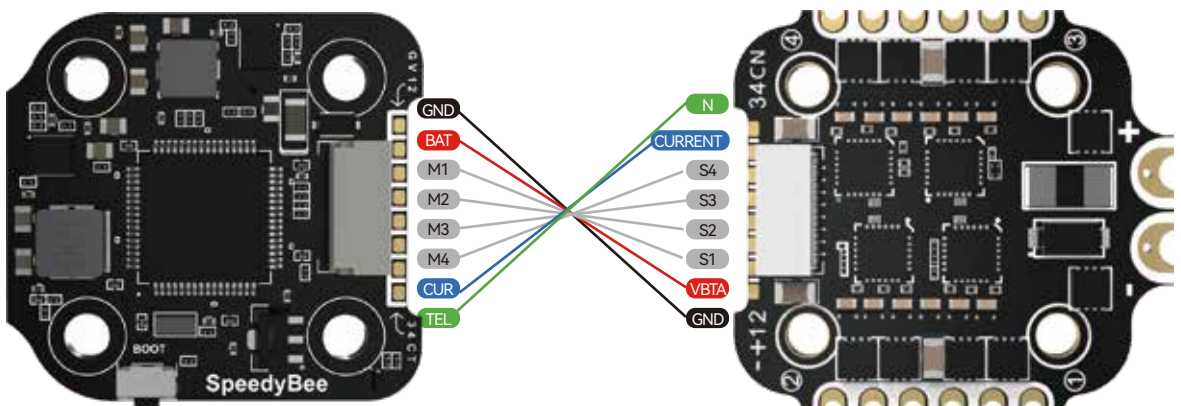

F405 Mini Flight Controller

BLS 35A Mini V2 4-in-1 ESC

# Part 2 SpeedyBee F405 Mini Flight Controller

## Layout

5/14

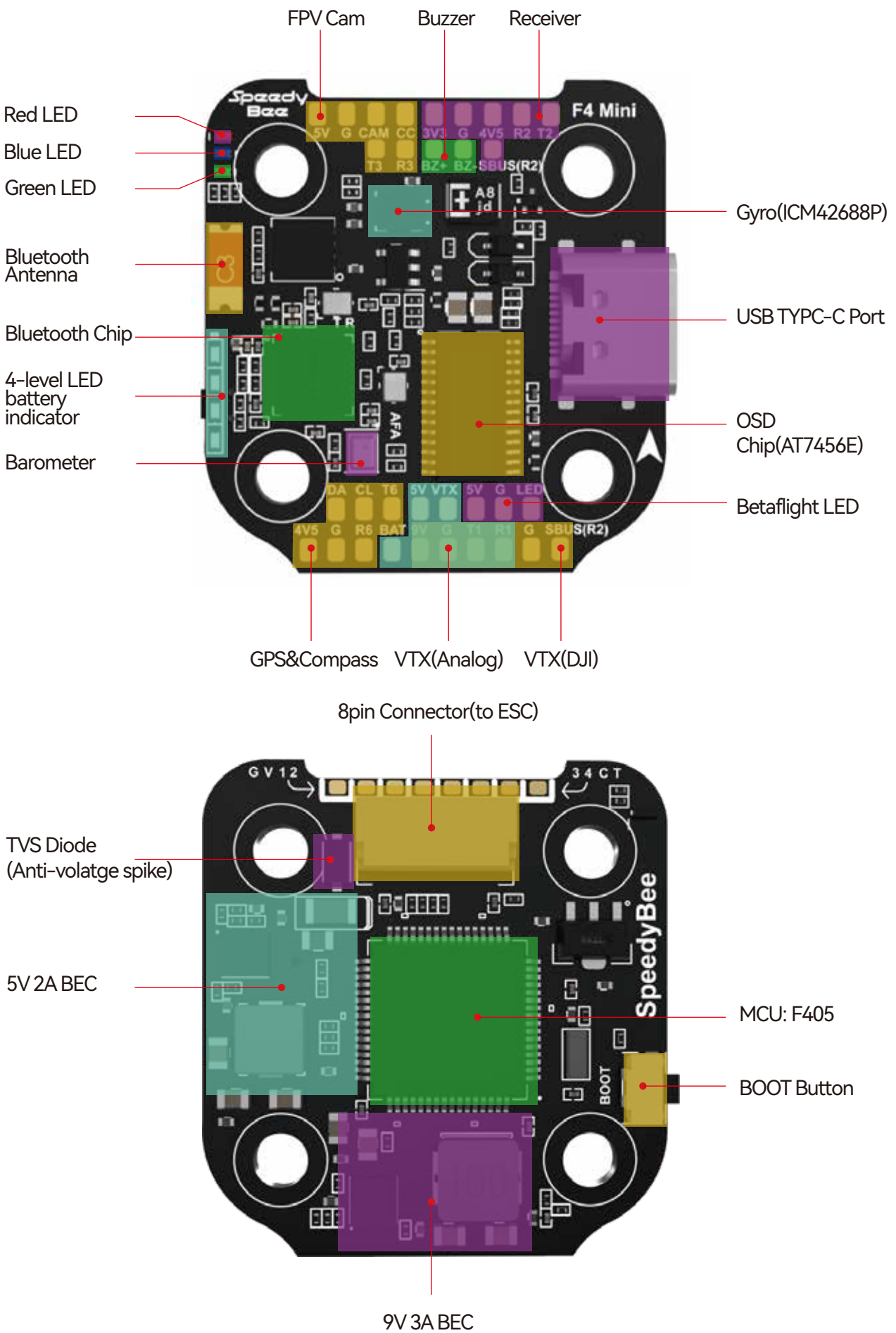

### LED Indicator Definition

- RED LED** - Power Indicator. **Solid Red** after powering up.
- GREEN LED** - Bluetooth status light. **Solid Green** indicates Bluetooth is connected.
- BLUE LED** - Flight controller status light which is controlled by the flight controller firmware.

### BOOT Button

Only if the flight controller gets bricked and can't power up, please follow these steps to re-flash firmware for it:

- ① Insert a USB A to TYPE-C cable to your PC.
- ② Press and hold the BOOT button, insert the USB cable into the flight controller, then release the BOOT button.
- ③ Open Betaflight/INAV configurator on the PC, go to the 'Firmware Flashing' page, choose the target 'SPEEDYBEEF405MINI' and flash.

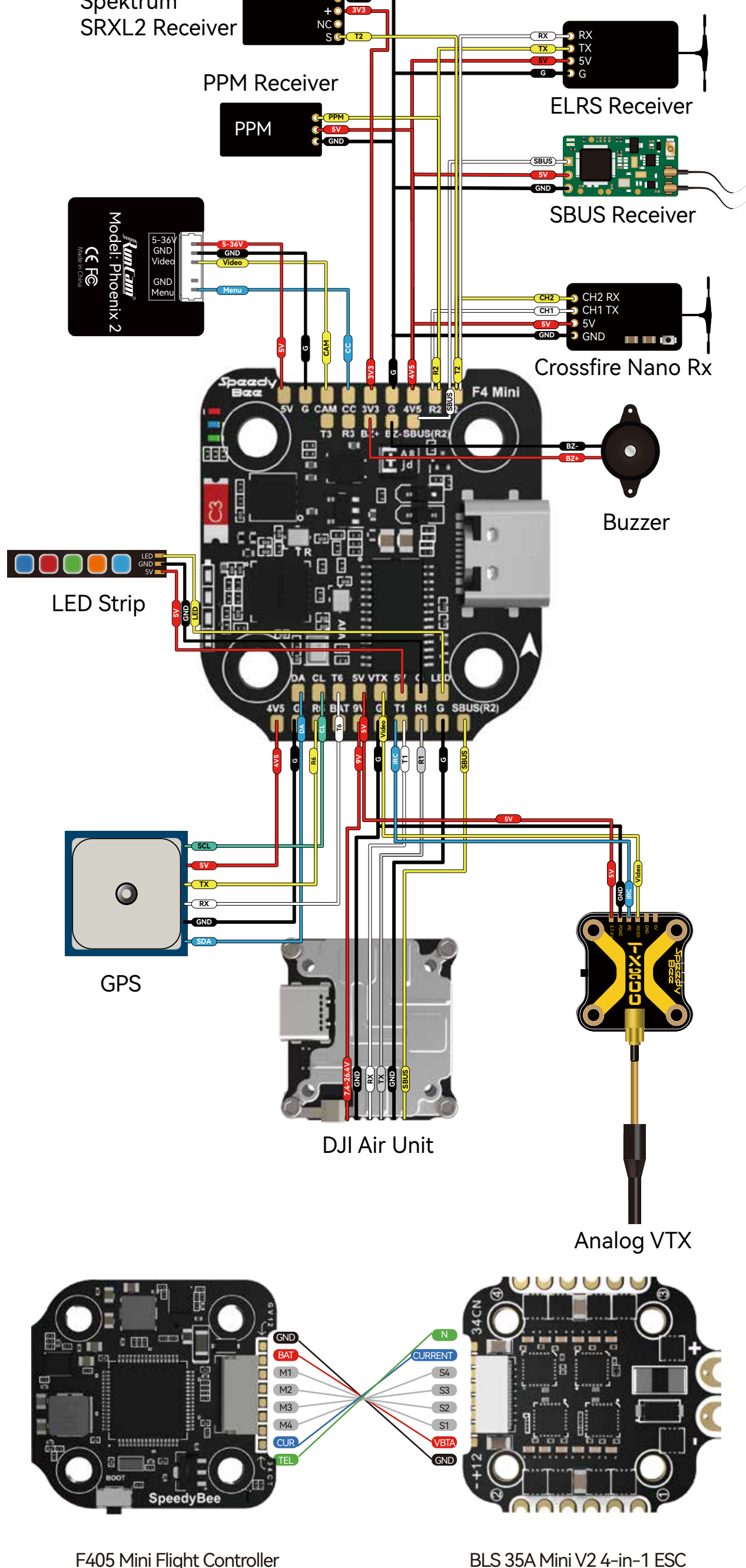

F405 Mini Flight Controller

BLS 35A Mini V2 4-in-1 ESC

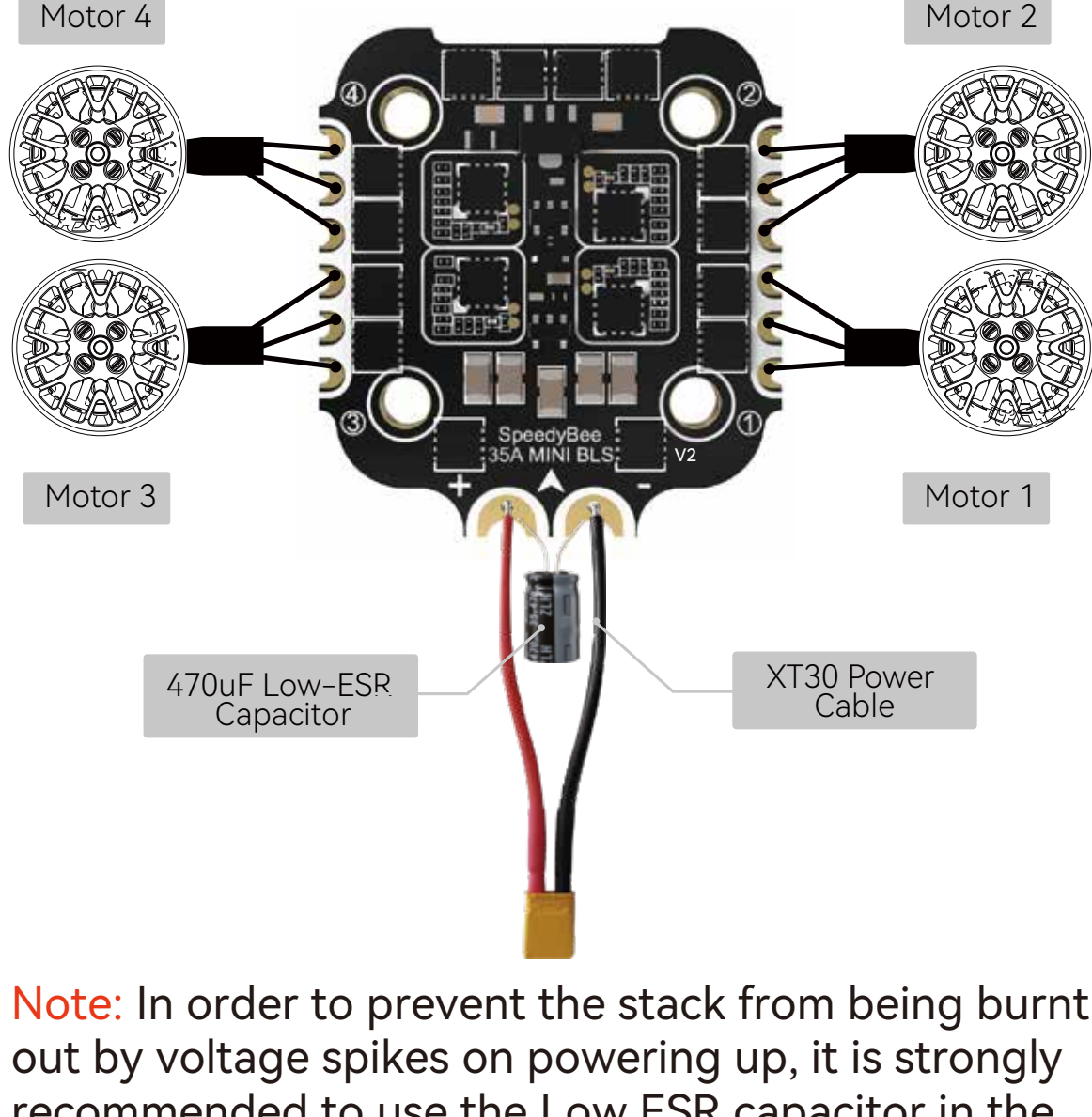

**Note:** In order to prevent the stack from being burnt out by voltage spikes on powering up, it is strongly recommended to use the Low ESR capacitor in the package.

**Cable Connection vs DJI O3 Air Unit**

Use the DJI 6-pin cable(80mm) comes with the F405 Mini stack(See the accessory No.6 in the package section). Cut off the 8-pin connector and keep the 6-pin connector. Use the 6-pin connector to connect to the DJI O3 Air Unit, and then solder the other end to the flight controller.

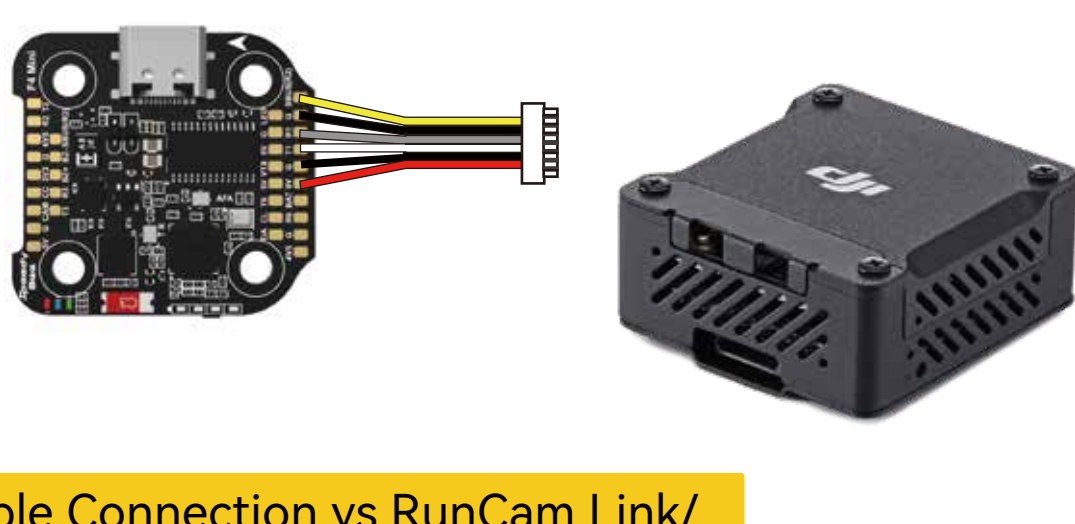

**Cable Connection vs RunCam Link/Caddx Vista Air Unit**

Use the DJI 6-pin cable(80mm) comes with the F405 Mini stack(See the accessory No.6 in the package section). Cut off the connectors on both ends and solder the 6 wires.

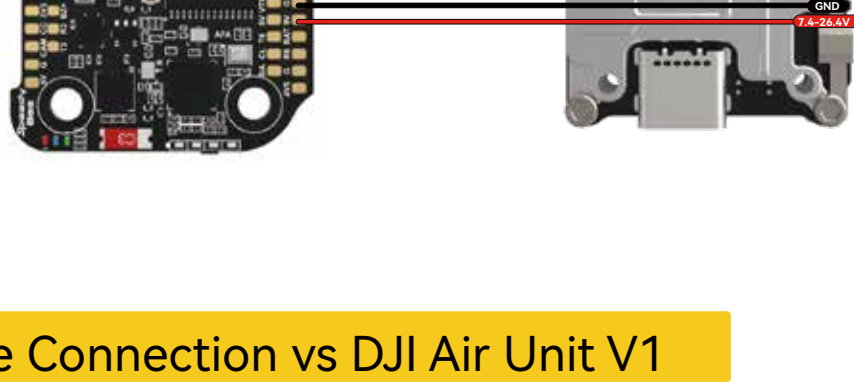

**Cable Connection vs DJI Air Unit V1**

Use the DJI 6-pin cable(80mm) comes with the F405 Mini stack(See the accessory No.6 in the package section). Cut off the 6-pin connector and keep the 8-pin connector. Use the 8-pin connector to connect to the DJI Air Unit V1, and then solder the other end to the flight controller.



**Important notice for SBUS receiver**

When using an SBUS receiver, the SBUS signal wire of the receiver must be connected to the SBUS pad on the front side of the flight controller (this pad internally uses UART2).

If you are also using the DJI Air Unit(O3/Link/Vista/Air Unit V1), you will need to disconnect the SBUS signal wire from the Air Unit harness. Failure to do so will prevent the SBUS receiver from being properly recognized by the flight controller. You can use tweezers to pick out the SBUS wire from the 6-pin harness connector (or directly cut this wire) and insulate the exposed part of the wire carefully.

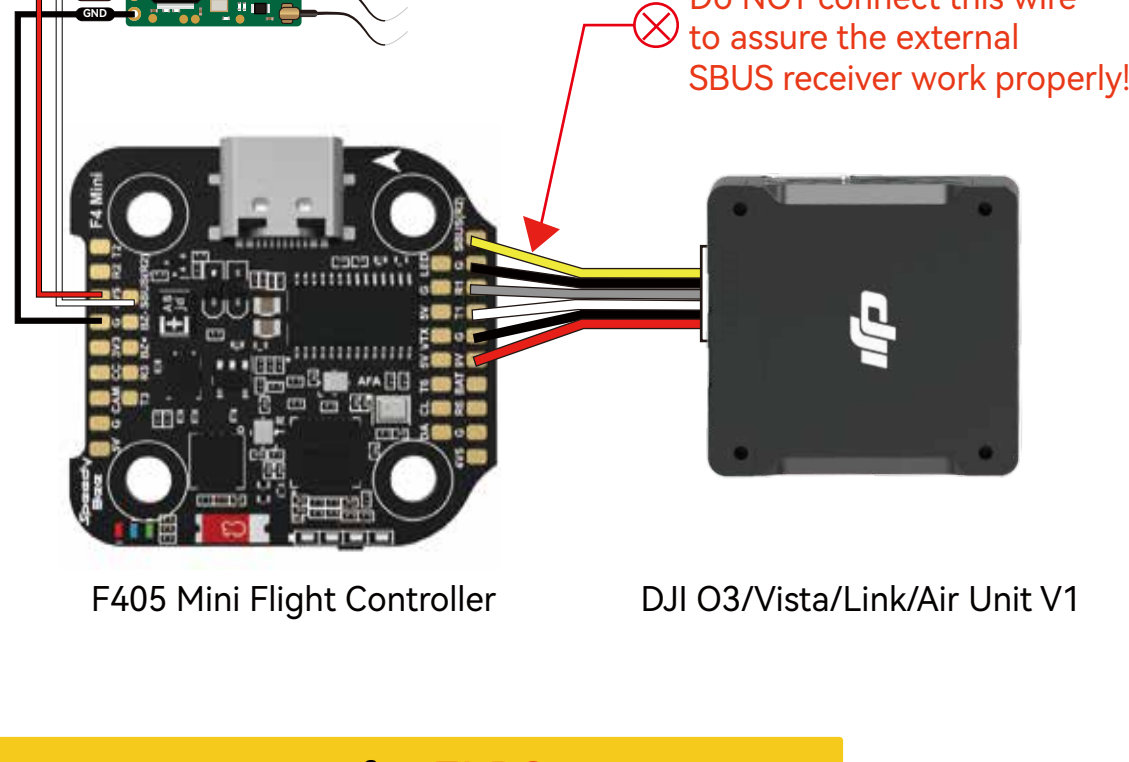

F405 Mini Flight Controller

DJI O3/Vista/Link/Air Unit V1

**Important notice for ELRS receiver**

We recommend connecting the ELRS receiver's TX and RX to the T2 and R2 pads on the flight controller. However, when using the DJI Air Unit simultaneously, some ELRS receivers may not be recognized properly by the flight controller. If you encounter this issue, you need to disconnect the SBUS signal wire from the Air Unit harness. You can use tweezers to pick out the SBUS wire from the 6-pin harness connector (or directly cut this wire) and insulate the exposed part of the wire carefully.

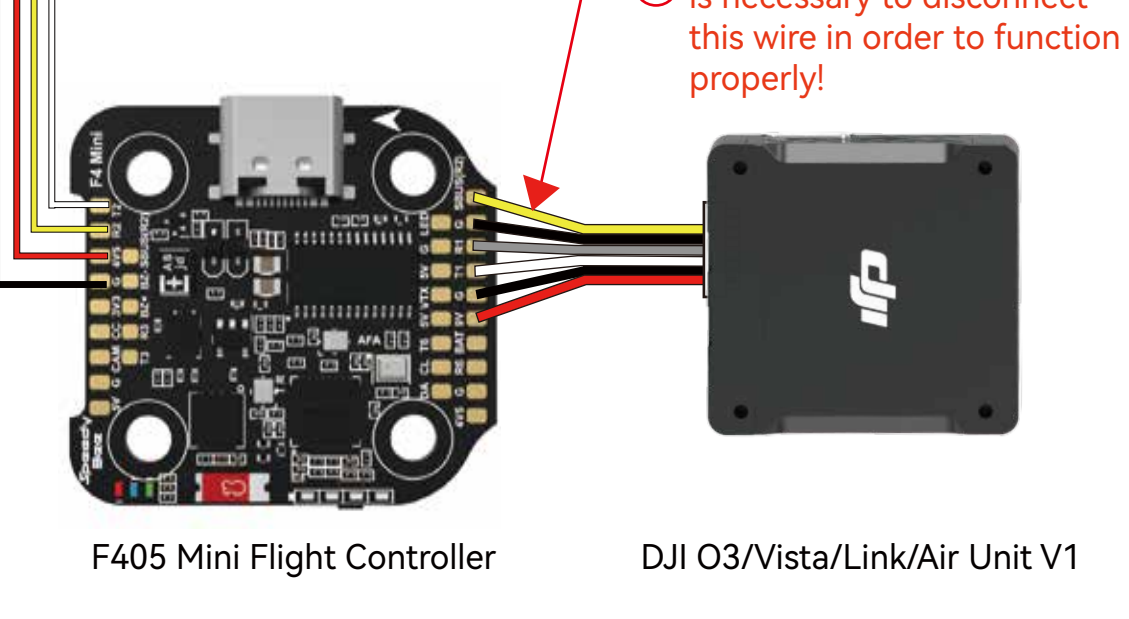

F405 Mini Flight Controller

DJI O3/Vista/Link/Air Unit V1

## ■ Get the SpeedyBee App

Search 'SpeedyBee' on Google Play or App Store. Or download the Android .apk file on our website: <https://www.speedybee.com/download>.

## ■ FC Configuration

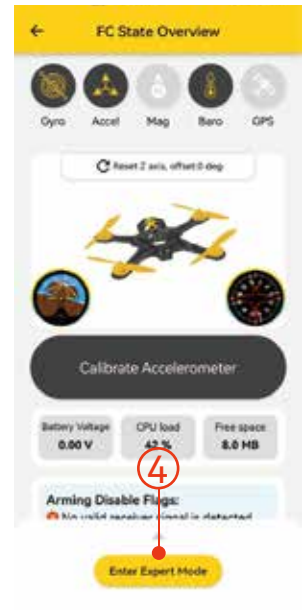
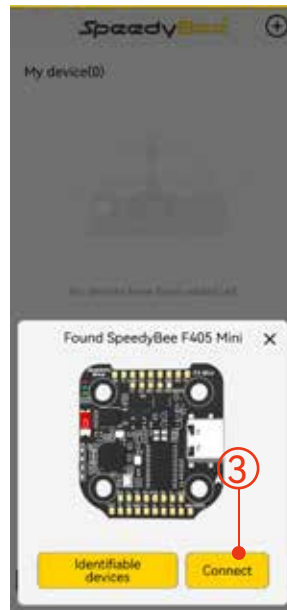
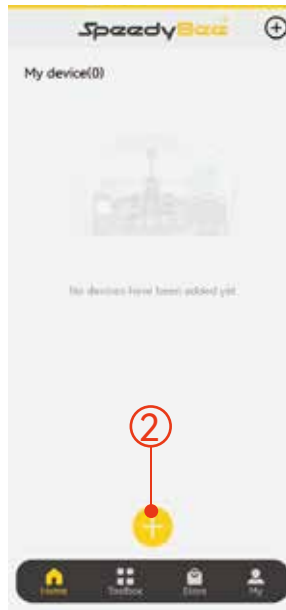
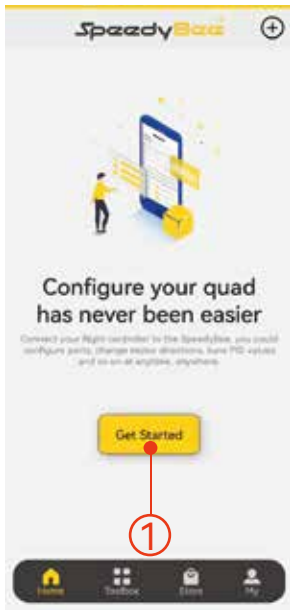



SpeedyBee F405 Mini flight controller does not support wireless firmware flashing, so please flash firmware for it on your PC following the steps below:

- ① Connect the flight controller to the PC with a USB cable
- ② Open Betaflight/INAV configurator on your PC. Take Betaflight configurator as an example, go to the 'Firmware Flashing' page, choose the target 'SPEEDYBEEF405MINI' and flash.

The screenshot shows the Betaflight Configurator interface. The main heading is 'Firmware Flasher'. Underneath, there's a dropdown menu for 'SPEEDYBEEF405MINI'. Below that, there are three checkboxes: 'No release sequence' (checked), 'Full chip erase' (unchecked), and 'Manual baud rate' (250000). A yellow 'Flash' button is on the right. A large red warning box is prominent, containing text about not flashing non-Betaflight hardware. Below the warning, there's a 'Build Configuration' section with 'Memory Protocol' set to 'None' and 'Motor Protocol' set to 'DSHOT'. At the bottom, there are buttons for 'Flash Firmware (Default)' and 'Flash Firmware (Custom)'. The left sidebar shows navigation options like 'Home', 'Flighting', 'Firmware Update', 'Community & Support', 'Forum', and 'Advanced Features'.



<b>Product Name</b>	<b>SpeedyBee F405 Mini Flight Controller</b>
MCU	STM32F405
IMU(Gyro)	ICM42688P
USB Porttype	Type-C
Barometer	Built-in
OSD Chip	AT7456E chip
BLE Bluetooth	Supported. Used to connect with the SpeedyBee App for flight controller and ESC parameter configuration. <b>Please make sure the MSP switch on UART 4 is turned on and set to a baud rate of 115200, otherwise Bluetooth functionality will not be available.</b>
WIFI	Not supported
Wireless FC Firmware Flashing	NOT Supported. Please connect to the Betaflight configurator on the PC to do FC firmeware update.
Wireless Blackbox Dwnload & Analysis	NOT Supported. Please connect to the Betaflight configurator on the PC to do blackbox analysis.
DJIAir Unit Connection Way	Direct soldering
DJI Air Unit Compatibility	Compatible with all DJI Air Units: DJI O3/RunCam Link/Caddx Vista/DJI Air Unit V1. Please use the solder pads <9V, G, T1, R1, G, SUBS(R2)> on the front right corner of the flight controller to make a pin-to-pin connection with the solder pads on the DJI Air Unit. <b>UART1(T1, R1) is used for OSD</b> and SUBS(R2) is used for DJI Air Unit's internal <b>SBUS receiver signal input</b> .
Blackbox	8MB Onboard Flash
BetaFlight Camera Control Pad	Yes(CC pad on the front side)
Current Sensor Input	Supported. For SpeedyBee BLS 35A V2 ESC, please set Scale=250 and Offset=-500.
Power Input	3-6S LiPo. The flight controller is powered through the G, V wires of the 8pin harness or G, V pads from the bottom side of the flight controller.
5V Output	4 groups of 5V output, three +5V pads and 1 BZ+ pad( used for Buzzer) on front side. The total current load is 2A.
9V Output	1 group of 9V output, one +9V pad on front side. The total current load is 3A.
3.3V Output	Supported. Soldering pad named '3V3' on the front top of the flight controller. Designed for 3.3V input receivers. Up to 500mA current load.
4.5V Output	Supported. Designed for radio receiver and GPS module even when the FC is powered through the USB port. Up to 1A current load.
ESC Signal	M1 - M4 wires or soldering pads on bottom side.
UART	6 sets(UART1, UART2, UART3, UART4(Dedicated for Bluetooth connection)), UART5(Dedicated for ESC telemetry),UART6
ESC Telemetry	UART R5(UART5)
I2C	Supported. DA & CL pads on front side. Used for magnetometer, sonar, etc
Traditional Betaflight LED Pad	Supported. 5V, G and LED pads on bottom of the front side. Used for WS2812 LEDs controlled by the Betaflight firmware.
Buzzer	BZ+ and BZ- pad used for 5V Buzzer
BOOT Button	Supported. Press and hold BOOT button and power the FC on at the same time will force the FC to enter DFU mode, this is for firmware flashing when the FC gets bricked.
RSSI Input	Not Supported
Smart Port / F.Port	Not Supported
Supported Flight Controller Firmware	BetaFlight(Default), INAV
Firmware Target Name	SPEEDYBEEF405MINI
Mounting	<b>20 x 20mm</b> $\phi$ 3.5mm hole diameter, <b>Compatible with M2 and M3</b> screws/Silicone grommets.
Dimension	30(L) x 32(W) x 7.8(H)mm
Weight	9.6g

# Part 3 SpeedyBee BLS 35A Mini V2 4-in-1 ESC

## Layout

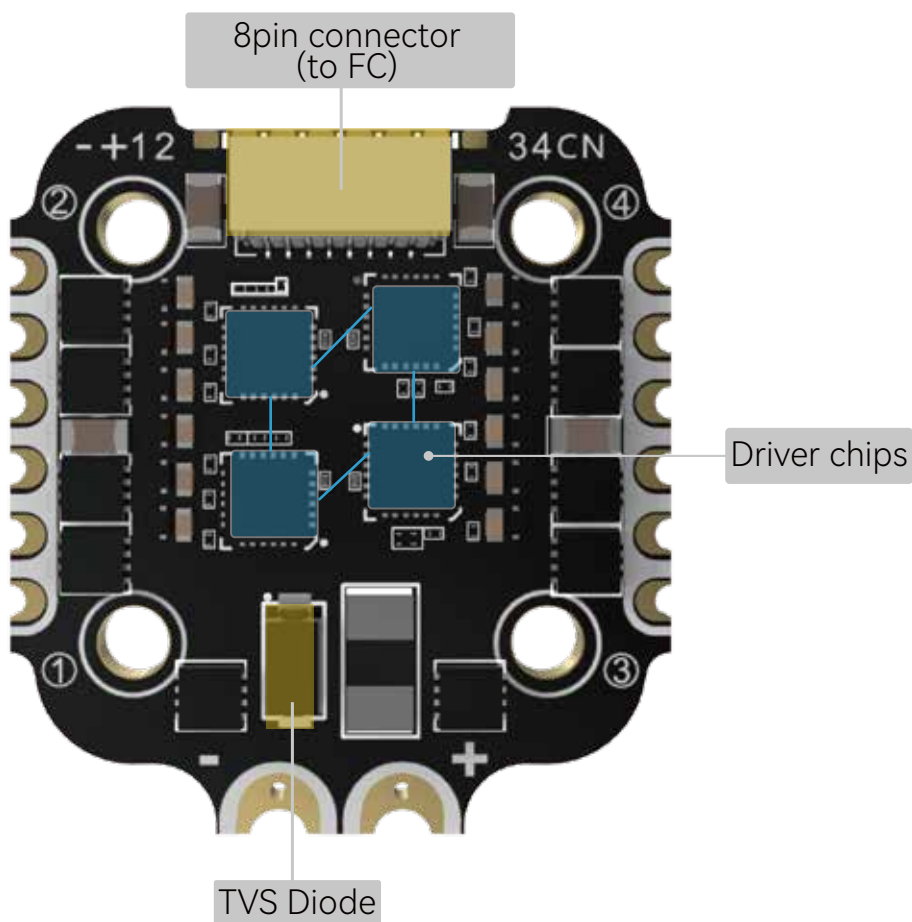
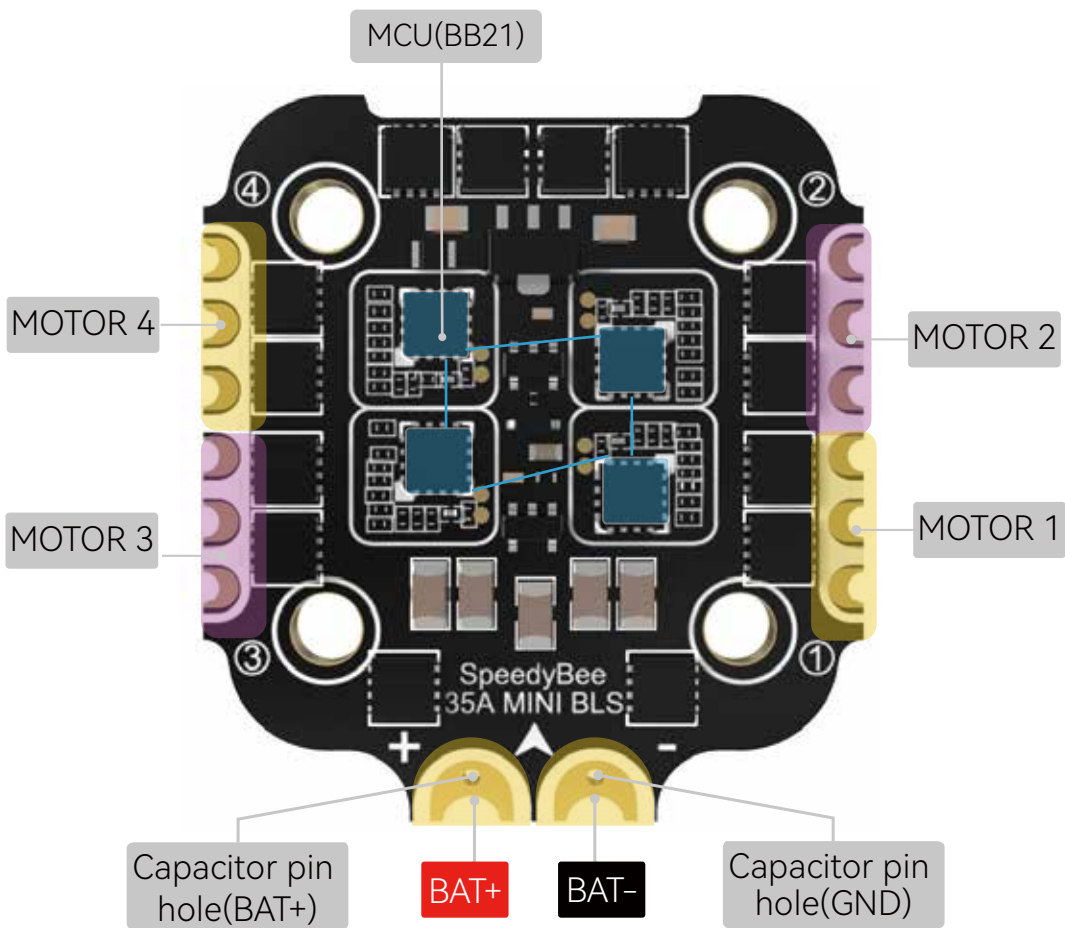

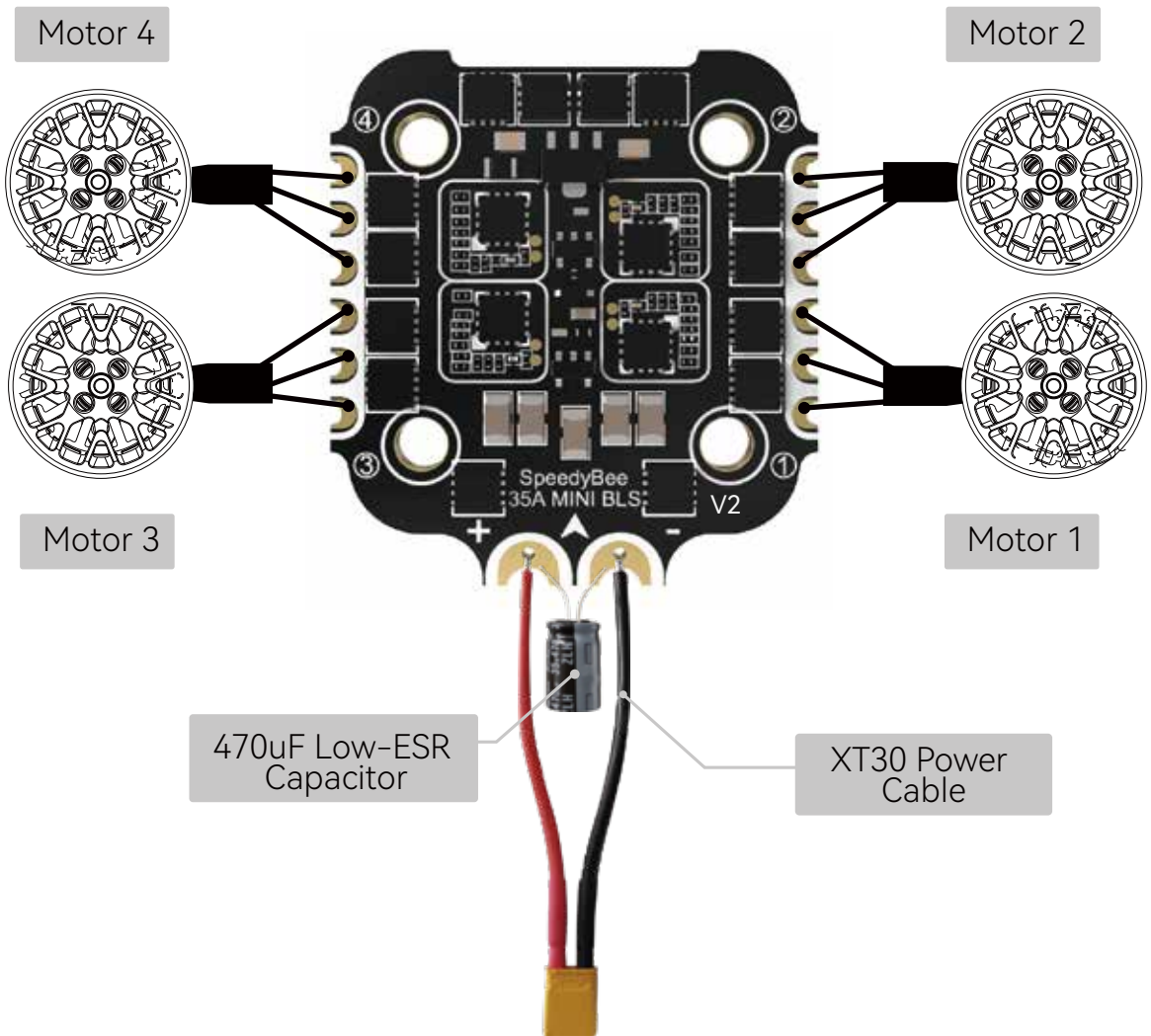

**Note:** In order to prevent the stack from being burnt out by voltage spikes on powering up, it is strongly recommended to use the Low ESR capacitor in the package.

You could use SpeedyBee app to completely configure this 8-bit ESC for both BLHeli\_S or Bluejay firmware. The steps are as follows:

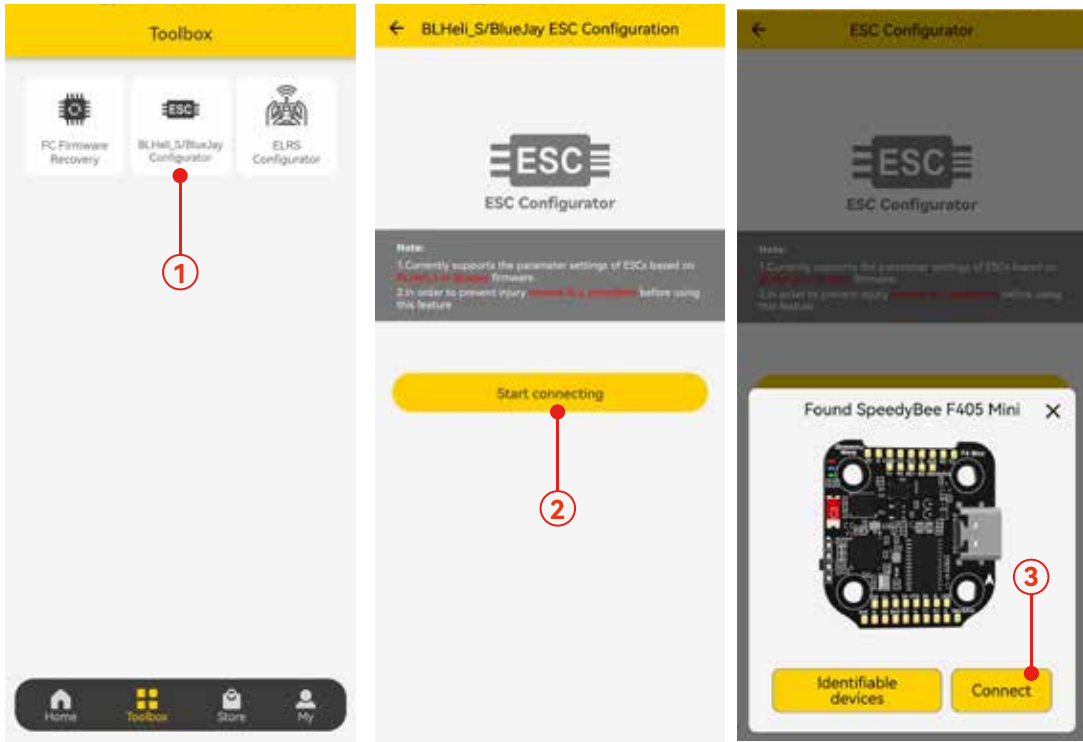

You could also use PC configurators to configure this ESC. We recommend the ESC Configurator. Please use Google Chrome browser and visit: <http://www.esc-configurator.com>.

This 8-bit 50A ESC can run BLHeliS or Bluejay firmware. It is loaded with BLHeliS firmware by default. You could also flash it to Bluejay firmware which can support RPM filtering and Bi-directional Dshot.

Firmware flashing steps are as follows:

- Remove all the propellers from your drone.
- Ensure that the flight controller is connected properly to the ESC, then power up the drone. This step ensures that the ESC starts up correctly.
- Connect the flight controller to the computer using a USB Type-C cable.
- Open the Chrome browser and visit the following website: <https://www.esc-configurator.com/>
- Follow the firmware flashing steps as shown in the screenshots below.

**Important note:**

On the 6th interface, the "ESC" type must be selected as "J-H-40".

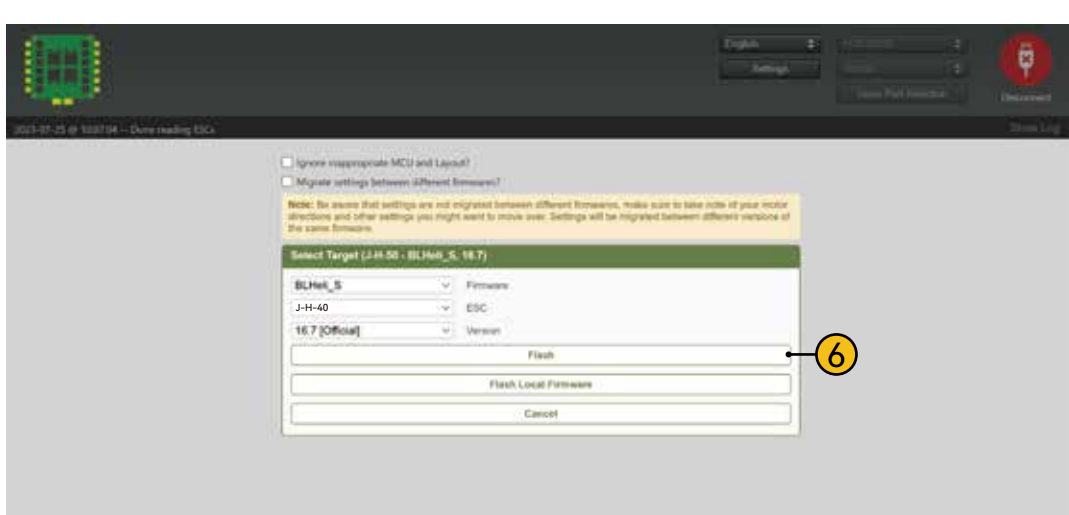
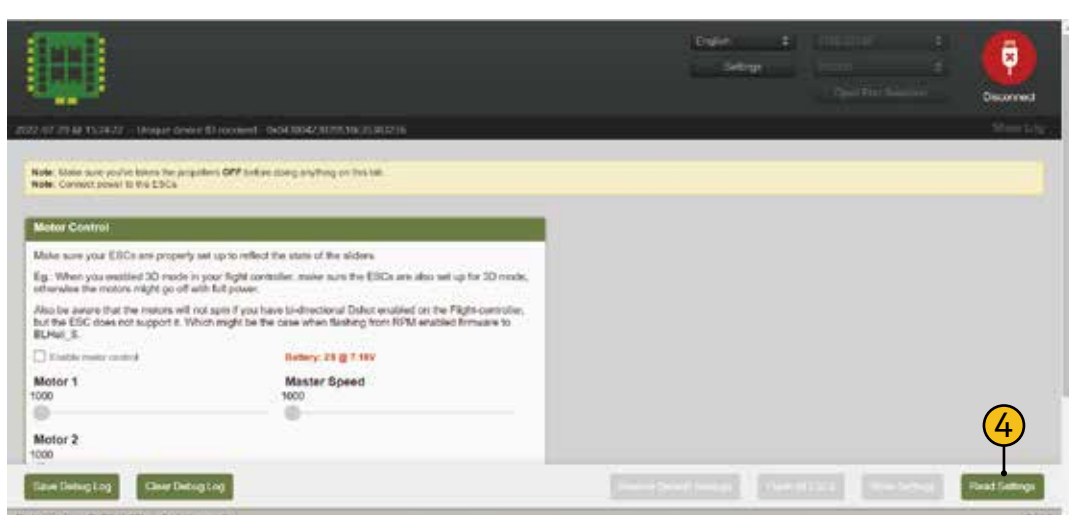
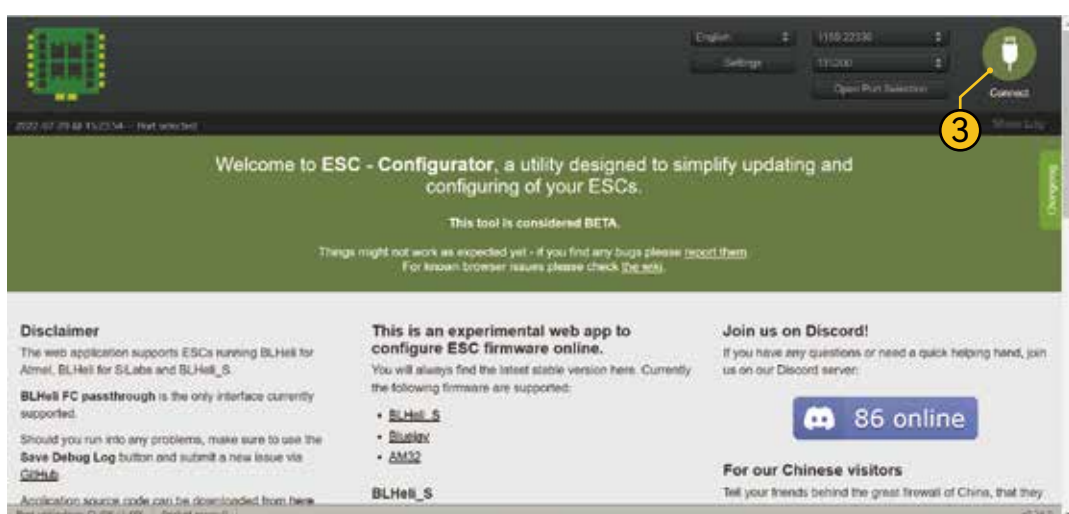
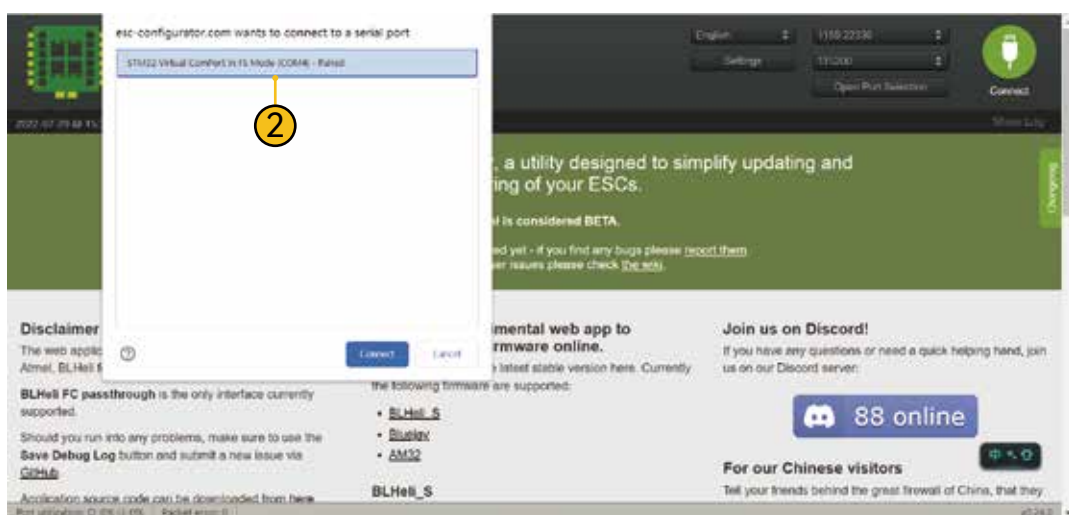
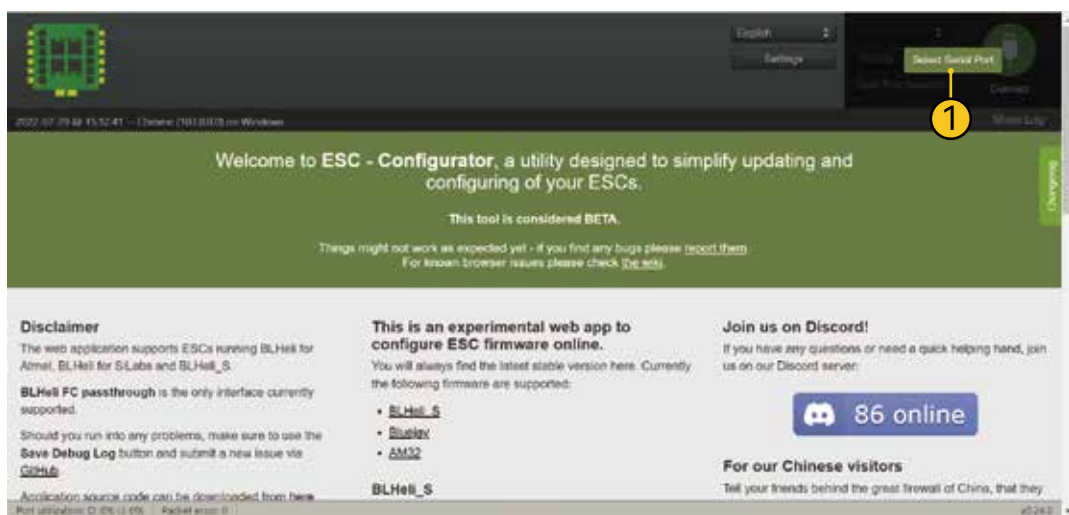



# Specifications

14/14

Product Name	SpeedyBee 35A BLHeli_S Mini V2 4-in-1 ESC
Firmware	BLHeli S J-H-40
Continuous Current	35A * 4
Burst Current	45A(5seconds)
ESC Protocol	DSHOT300/600
Power Input	3-6S LiPo
Power Output	VBAT(Battery voltage, used to power the flight controller)
Current Sensor	Support (Scale=250 Offset=-500)
ESC Telemetry	Not supported
Mounting	20 x 20mm $\Phi$ 3.5mm hole size, compatible with M2 and M3 screws/Silicone grommets.
Dimension	35 * 35 * 5.5mm
Weight	7.2g